

---

**Vision system**  
**AVS series**

## Specification basic information

This manual prepared by ADTECH(Shenzhen) Technology Co., Ltd organization.

The main writer of this specification: Wang Bing. This specification was first published in October 12, 2015, version number 15.11.12.09, project number BZ001B182A.

### Copyright notice

All parts of this manual, property rights in a work return Adtech (shenzhen) Technology Co., Ltd. (hereinafter referred to as Adtech) all, not with the permission of the Adtech, any unit or individual can not be arbitrary imitation, copy, copy the Zhuan or translation. The manual without any form of guarantee, expression of the position or other hints. Such as information by the manual or the mentioned products, caused by direct or indirect information flow, loss of profits or cause for termination, Adtech and staff does not assume any responsibility. In addition, refer to the manual products and information is for reference only, content for the updated without prior notice.

All rights reserved.

**Adtech (Shenzhen) technology Co.,Ltd**

- ☞ **Note note**
- ☞ **The transportation and storage.**
- ☞ **Product packing box can not be stacked more than six layers**
- ☞ **Do not climb, stand or place heavy objects on the packing case.**
- ☞ **Do not use a cable to drag or move products attached to the product**
- ☞ **No collision, scratch panel and display**
- ☞ **The product packaging box should avoid exposure to rain and wet.**
- ☞ **Please check out of the box**
- ☞ **After opening the package, please confirm whether it is the product you are buying.**
- ☞ **Check whether there is any damage to the goods during transit**
- ☞ **Control list to confirm that the parts are complete, there is no damage**
- ☞ **If the product model does not match, the lack of attachment or transport damage, please contact our company in a timely manner**
- ☞ **The wiring**
- ☞ **To participate in wiring and inspection personnel must have the corresponding capacity of professionals**
- ☞ **Products must be reliable grounding, grounding resistance should be less than 4 ohm, can not use the neutral line (zero line) instead of the ground**
- ☞ **Connection must be correct and firm, so as not to result in product failure or unexpected consequences.**
- ☞ **The surge absorbing diode connected with the product must be connected in accordance with the regulations, otherwise it will damage the product.**
- ☞ **Plug or open the product case before, must be cut off the power supply**
- ☞ **The maintenance**
- ☞ **Power supply must be cut off before servicing or replacing components**
- ☞ **In the occurrence of short circuit or overload should be checked for failure, failure to remove the rear can be re activated**
- ☞ **Products are not frequent power outages, power outages if required to re energized, separated by at least 1 minutes**
- ☞ **The other**
- ☞ **Without permission, please do not open the case without authorization.**
- ☞ **Please cut off the power when you don't use it for a long time.**
- ☞ **Special attention not to let dust, iron into the controller.**
- ☞ **Relay output if the use of non solid state relay shall be in the relay coil parallel free wheeling diode. Check the connected power supply whether it meets the requirements, put an end**

to the burnout of controller.

- ☞ The life of the controller has a great relationship with the environment temperature. If the temperature is too high, please install the cooling fan. The controller allows the working environment temperature range between 0 and -60.
- ☞ Avoid the use of high temperature, humidity, dust or corrosive gases.
- ☞ In strong earthquake place, should be added with rubber shock pad buffer.
- ☞ The maintenance
- ☞ In general conditions of use (environmental conditions: daily average 30 degrees, load rate of 80%, the operating rate of 12 hours per day), please follow the following items for daily inspection and regular inspection.

|             |             |               |
|-------------|-------------|---------------|
| Daily check | Daily check | ● Daily check |
| daily       | daily       | ● daily       |
| Daily check | Daily check | ● Daily check |

## Content

|  |                                     |
|--|-------------------------------------|
| <b>CONTENT</b> .....   | Error! Bookmark not defined.        |
| <b>Overview</b> .....  | Error! Bookmark not defined.        |
| <b>The first chapter product introduction</b> .....              | Error! Bookmark not defined.        |
| <b>The second chapter is the main performance</b> .....          | Error! Bookmark not defined.        |
| 2.1 HARDWARE PERFORMANCE DESCRIPTION: .....                      | <b>ERROR! BOOKMARK NOT DEFINED.</b> |
| 2.2 SOFTWARE PERFORMANCE DESCRIPTION: .....                      | <b>ERROR! BOOKMARK NOT DEFINED.</b> |
| <b>The third chapter is the scope of application</b> .....       | <b>7</b>                            |
| 3.1 DESCRIPTION: .....   | <b>ERROR! BOOKMARK NOT DEFINED.</b> |
| <b>Hardware chapter</b> .....                                    | Error! Bookmark not defined.        |
| <b>Chapter 1 hardware installation</b> .....                     | Error! Bookmark not defined.        |
| 1.1 PRODUCT CONFIGURATION: .....                                 | <b>ERROR! BOOKMARK NOT DEFINED.</b> |
| 1.2 INSTALLATION DIMENSIONS: .....                               | <b>ERROR! BOOKMARK NOT DEFINED.</b> |
| <b>The second chapter electrical connection</b> .....            | Error! Bookmark not defined.        |
| 2.1 SRM1000 ELECTRICAL INTERFACE .....                           | 11                                  |
| 2.2 CAMERA ELECTRICAL INTERFACE .....                            | 12                                  |
| <b>The third chapter working environment</b> .....               | <b>21</b>                           |
| 3.1 SRM1000 WORK ENVIRONMENT: .....                              | 21                                  |
| 3.2 CCD CAMERA WORKING ENVIRONMENT: .....                        | 21                                  |
| <b>Software articles</b> .....                                   | Error! Bookmark not defined.        |
| <b>Chapter 1 ADTVision function description</b> .....            | <b>22</b>                           |
| <b>Chapter 1 ADTVision interface description</b> .....           | <b>22</b>                           |
| 1.1 MAIN INTERFACE .....   | 22                                  |
| 1.2 MAIN TOOLBAR .....   | 23                                  |
| 1.3 DISPLAY AREA .....   | 24                                  |
| 1.4 PROCESS JOB AREA .....                                       | 24                                  |
| 1.5 TOOL BOX BAR .....   | 24                                  |
| 1.6 OUTPUT INFORMATION .....                                     | 24                                  |
| <b>The second chapter ADTVision operating instructions</b> ..... | <b>25</b>                           |
| 2.1 NEW PROJECT .....  | 25                                  |
| 2.2 JOB FLOW EDITOR .....  | 25                                  |
| <b>The third chapter ADTVision tool description</b> .....        | <b>26</b>                           |
| 3.1 COLLECTING IMAGE .....                                       | 26                                  |
| 3.2 STORAGE IMAGE .....  | 27                                  |
| 3.3 POSITIONING TOOL .....                                       | 28                                  |
| 3.4 CALIBRATION TOOL .....                                       | 33                                  |
| 3.5 SERIAL PORT .....  | <b>ERROR! BOOKMARK NOT DEFINED.</b> |
| 3.6 ETHERNET .....   | 36                                  |
| <b>Appendix a common problem of camera handling</b> .....        | <b>37</b>                           |

## An overview

### The first chapter product introduction

AVS system main function is to locate, use friendly interface of the PC software ADT vision, only need to through a few simple drag and drop operation can quickly construct their own visual positioning system, and by now the most popular Ethernet and serial industrial network and I / O connected to the output port of the positioning results rapid return to the PLC and various types of controller. Available in a variety of high accuracy position information of industrial equipment and robotic systems.

The whole system mainly includes two parts of hardware and software:

Hardware part: micro computer + camera + lens + light source

Software part: ADT Vision software

The second chapter is the main performance

### 2.1 hardware performance description:

- ★It has the advantages of small volume, easy installation and integration
- ★no fan design, low power consumption, good heat dissipation performance
- ★support Gigabit Ethernet, USB and other different camera interface
- ★Using stable performance, high imaging quality array CCD camera.
- ★The powerful processor can effectively reduce the system positioning time  
Operating system. The stability of online or offline detection
- ★support RS232, Ethernet, and so on a variety of common communication interface.
- ★Easy to integrated into the factory environment, in line with the OPC standard
- ★ For end users and system integrators and manufacturers to provide the perfect solution.

### 2.2 software performance description:

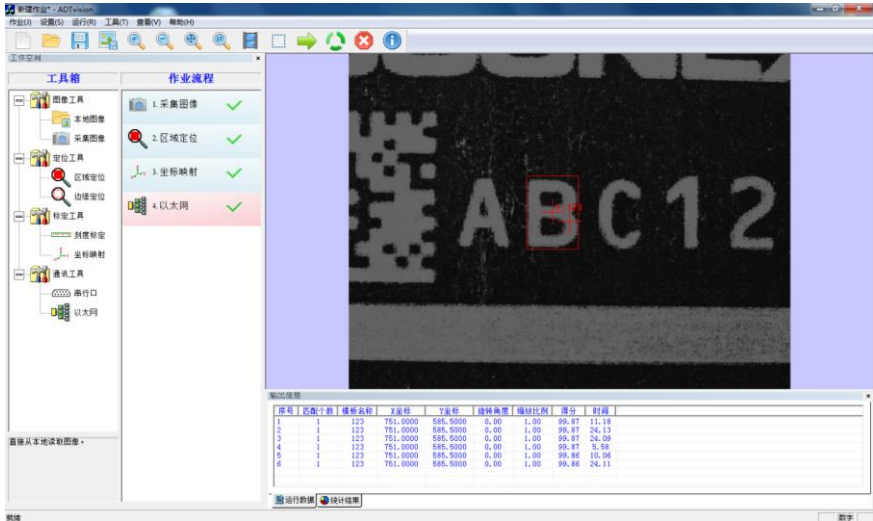

- ★Using Sapera Processing image processing algorithm library Canada famous CCD manufacturer DALSA, the algorithm has high accuracy and strong stability
  - ★The theory of 'localization algorithm can reach 1/64 pixel accuracy, can output the position, rotation and zoom ratio etc.
  - ★It supports multi camera scheme, multiple cameras can be collected at the same time, at the same time positioning
  - ★It supports different resolution and different camera interface
  - ★It supports the import of local image to simulate the camera function, can be used for off-line design and verification of positioning scheme
  - ★provide two positioning tool, edge positioning tool can quickly locate a clear outline of the objects, and can be computed for arbitrary rotation angle; regional positioning tool suitable for the irregular shape, low contrast objects
  - ★It provides two kinds of calibration tools will be converted into real physical pixel units, the calibration tool can also correct lens and perspective distortion
  - You drag work, intuitive operation efficiency, can quickly construct their own visual positioning system
  - ★Rich communication interface, support network, serial port, file reading and writing, the positioning results fast output to external control system, or a file system.
  - ★ Support new process, save and read and has built good work flow can be saved into a local file, the next application can be loaded directly, without any settings.
- The third chapter is the scope of application

### 3.1 description:

- Industrial robot equipment;
- Visual dispensing industry;
- Semiconductor packaging industry: solid crystal machine;
- Packaging and printing equipment, printing machine, printing machine;
- Automatic assembly equipment;
- PCB processing, SMT and other industries;

## Hardware chapter

### Chapter 1 hardware installation

#### 1.1 product configuration:

| configure              | model                 | AVS6630-00E   | AVS6650-00E                             |
|------------------------|-----------------------|---|---|
| Image unit             | characteristic        | Support single camera, multi camera   | Support single camera, multi camera     |
| storage<br>(SRM1000)   | CPU                   | Core N2600 1.6GHz   |   |
|                        | Memory                | 4G  |   |
|                        | Hard disk             | 16G Solid hard disk   |   |
|                        | Material Science      | High strength aluminum alloy  |   |
|                        | size                  | (Long * wide * high) 170mm*110mm*60mm   |   |
|                        | weight                | 2.0kg   |   |
| camera<br>(MER Series) | digital camera        | GIGE  |   |
|                        | input                 | 2Optical isolation input interface, 2Optical isolation output interface, 4 bidirectional GPIO |   |
|                        | format                | Surface scan  |   |
|                        | Pixel / resolution    | 30Million pixels CCD, 656(H)×492(V)   | 200 Million pixels CCD, 1628(H)×1236(V) |
|                        | frame rate            | 120fps  | 14fps                                   |
|                        | Synchronous mode      | External trigger, soft trigger  |   |
|                        | shutter               | 20μs~1s   |   |
|                        | Rated power           | <3W   |   |
|                        | Lens interface        | C   |   |
|                        | Mechanical Dimensions | 29mm*29mm*29mm  |   |
|                        | weight                | 42g   |   |
|                        | authentication        | RoHS , CE , GigE Vision, GenICam  |   |

|               |                 |  |
|---------------|-----------------|--|
|               | n               |  |
| communication | USB             | 6 USB 2.0Interface   |
|               | Ethernet        | 2 RJ45 network interface, 10/100/1000Mbps                    |
|               | serial port     | 4 x RS232  |
|               | Indicator light | 1 Status display lamp  |
| display       | local           | 24bit LVDS& VGA Interface synchronous or asynchronous output |
| Currency I/O  | input           | nothing  |
|               | output          | nothing  |
| Software      | ADTVision       | 2.0  |

## 1.2 mounting dimensions:

### 1.2.1 SRM1000 installation dimensions:

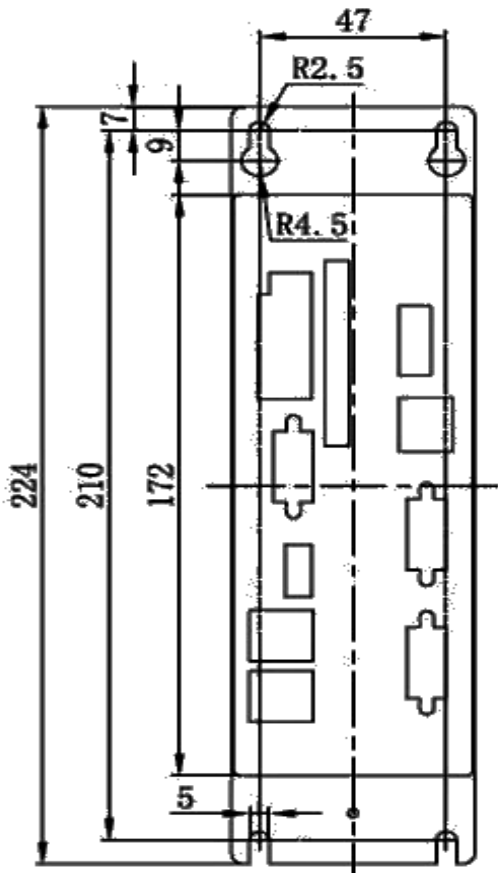



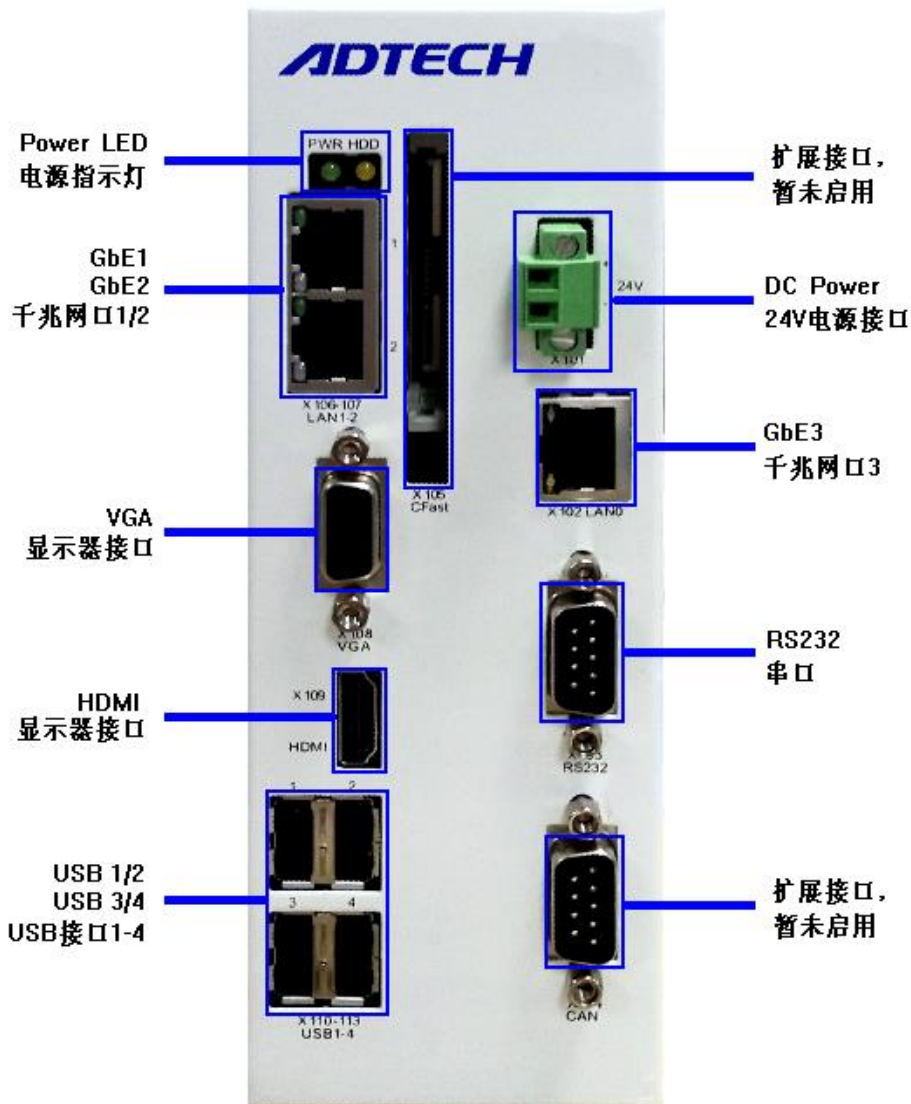

## 2.2 Camera electrical interface

Electrical interface includes three parts: network port, indicating lamp and IO interface. Camera through the web interface and host data exchange; control signal input, output and the camera power supply were by the IO interface implementation; indicator lights to indicate the working state of the camera.

### 2.2.1 Net port:

Net port connector is a standard RJ45 socket, pin defined in accordance with the Ethernet standard.

Net port supports Cat5e or Cat6 class cable for 100m.

### 2.2.2 Indicator light:

The rear shell of the camera is provided with a LED indicator for indicating the status of the camera, the LED indicator light can display 3 colors, namely red, yellow and green.

| LED state                     | Indicator camera status                              |
|-------------------------------|--|
| Go out                        | The camera does not go up.                           |
| The green light is always on. | Network has been connected, but no data transmission |
| Green flicker                 | Network port data transmission                       |
| other                         | Camera internal state                                |

### 2.2.3 IO interface:

The IO interface uses a 8-pin Hirose round head socket.

| Sketch Map | Pin | Definition | Explain                               |
|------------|-----|------------|---------------------------------------|
|            | 1   | Line0+     | Optocoupler input positive            |
|            | 2   | GND        | Camera power supply, GPIO             |
|            | 3   | Line0-     | Optocoupler input negative            |
|            | 4   | POWER_IN   | Camera external power supply, DC +12V |
|            | 5   | Line2      | GPIO Input / output                   |
|            | 6   | Line3      | GPIO Input / output                   |
|            | 7   | Line1-     | Optocoupler input negative            |
|            | 8   | Line1+     | Optocoupler input positive            |

MER series digital camera input power supply must use +12V (+ 10%) DC power supply, power supply through the IO interface.

Note: the power supply polarity cannot be reversed, otherwise it will burn out the camera or camera connected to other devices.

GPIO polarity cannot be reversed, otherwise it will burn out the camera or camera connected to other devices.

### 2.2.3 IO Interface:

#### 2.2.3.1 Line0 (optocoupler input) circuit

Optocoupler input circuit principle diagram as shown in Figure 3-1, the dotted line in the box for the external circuit.

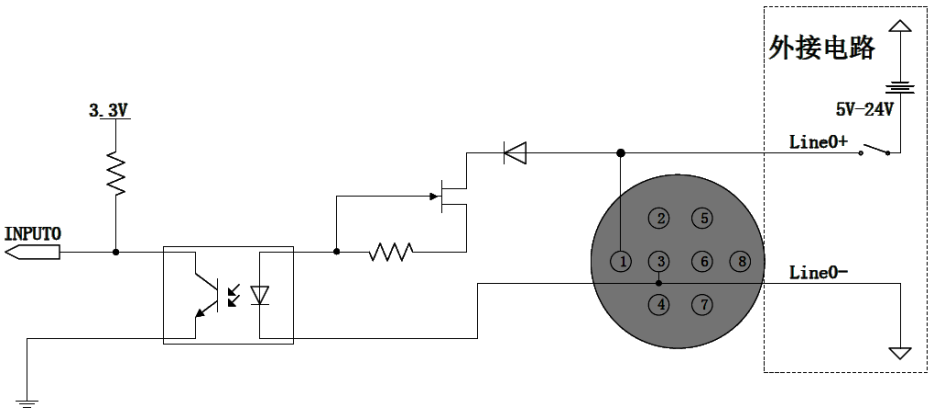

□□ Figure 3-1 optocoupler input circuit

- Logic 0 input voltage: 0V~+2.5V (Line0+ terminal voltage)
- Logic 1 input voltage: +5V~+24V (Line0+ terminal voltage)□□
  - Max input current: 7mA
- Input voltage between the 2.5V~5V for the uncertain state, should avoid the input voltage within this interval value.
- Rising along the delay time: <50 s (0 C ~45 C), the parameters are shown in figure 3-2.
- Falling edge delay time: <50 s (0 C ~45 C), the parameter description see figure 3-2.
- Different ambient temperature and input voltage will have an impact on the

delay time. When the environment temperature is 25°C, The time delay of the typical application environment is shown in the following table:

| Parameter          | Test condition | Value(us) |   |       |
|--------------------|----------------|-----------|---|-------|
|                    |                |           | ~ |       |
| Rising edge delay  | VIN=5V         | 3.02      | ~ | 6.96  |
|                    | VIN=12V        | 2.46      | ~ | 5.14  |
| Falling edge delay | VIN=5V         | 6.12      | ~ | 17.71 |
|                    | VIN=12V        | 8.93      | ~ | 19.73 |

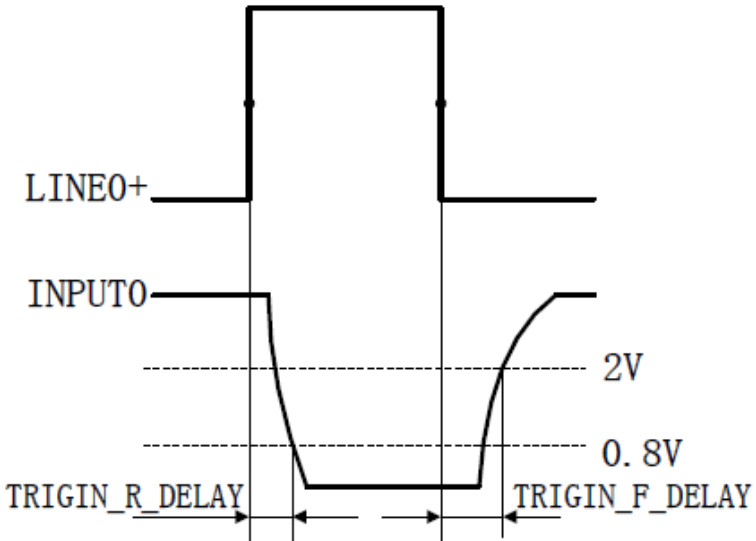
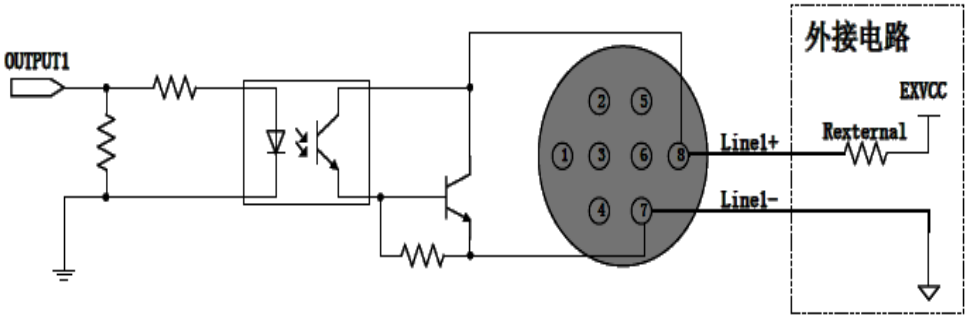

Figure 3-2 optocoupler input circuit parameters

**2.2.3.2 Line1 (optocoupler input) circuit**

Optocoupler output circuit principle diagram as shown in Figure 3-3, the dotted line in the box for the external circuit.



□□ Figure 3-3 optocoupler input circuit

□□ The EXVCC range of the external voltage is 5~24V

□□ Line1 maximum output current 25mA

□□ When the environment temperature is 25°C, the output voltage and output current in typical application environment are shown in table 3-4:

| External voltage<br>(EXVCC) | External resistance<br>Rexternal | Output voltage<br>drop (V) | Output current (mA) |
|-----------------------------|----------------------------------|----------------------------|---------------------|
| 5V                          | 1KΩ                              | 0.9                        | 4.16                |
| 12V                         | 1KΩ                              | 0.97                       | 11.11               |
| 24V                         | 1KΩ                              | 1.04                       | 23.08               |

□□ On the rise time delay= $t_r+t_d$ :  $<50\mu s$  (0°C~45°C), The parameter description is shown in figure 3-4:

□□ Falling edge delay= $t_s+t_f$ :  $<50\mu s$  (0°C~45°C), The parameter description is shown in figure 3-4:

When the environment temperature is 25°C, delay time in typical application

environment:

| Parameter                     | Test condition                                 | Value (us) |   |       |
|-------------------------------|--|------------|---|-------|
| Storage time $t_s$            | External power supply 5V, Pull up resistor 1kΩ | 6.16       | ~ | 13.26 |
| Delay Time $t_d$              |  | 1.9        | ~ | 3.16  |
| Rise time $t_r$               |  | 2.77       | ~ | 10.6  |
| Fall time $t_f$               |  | 7.6        | ~ | 11.12 |
| Rising edge delay= $t_r+t_d$  |  | 4.7        | ~ | 13.76 |
| Falling edge delay= $t_f+t_s$ |  | 14.41      | ~ | 24.38 |

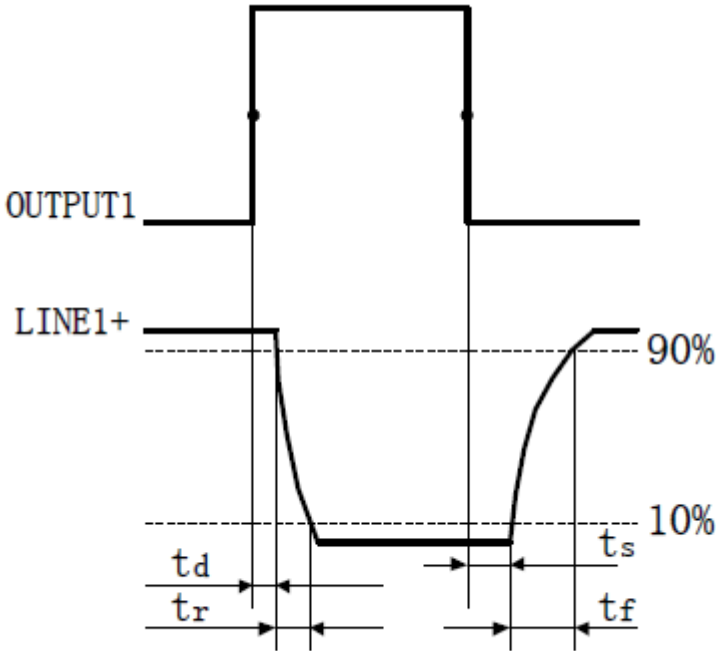

Figure 3-4 optocoupler output circuit parameters

□□ Delay time  $T_d$ : from the OUTPUT1 amplitude of half to LINE1+ down to LINE1+ amplitude 90% of the time.

□ Down time  $t_f$ : LINE1+ from 90% down to 10% of the time.

□□ Storage time  $t_s$ : from half of the OUTPUT1 amplitude to LINE1+ up to LINE1+ amplitude 10% of the time.

□□ The rise time of  $t_r$ : LINE1+ increased from 10% to 90% of the time.

**2.2.3.3 GPIO2/3 (bidirectional) circuit**

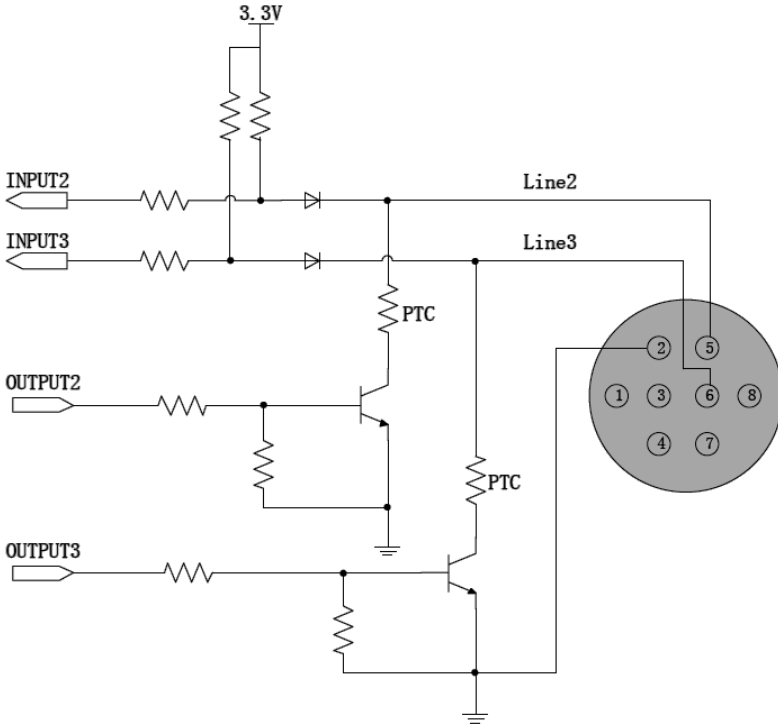

Figure 3-5 GPIO2/3 (bidirectional) circuit

Line2/3 Configured to input pins:

□ Logic 0 input voltage: 0V~+0.6V (Line2/3 terminal voltage)

Logic 1 input voltage: +1.9V~+24V (Line2/3 terminal voltage)

□ Input voltage between the 0.6V~1.9V for the uncertain state, the input signal should avoid entering this voltage range.

□ Line2/3 input high voltage, input current is less than Line2/3; 100uA input low

power, the input current is less than -1mA.

LINE2/3 as input, corresponding to the output device if it is common anode connection, the pull-down resistor not more than 1K, otherwise it will lead to LINE2/3 the input voltage is greater than the 0.6V, can not stabilize the recognition for a logic 0.

Rising input along delay:  $< 2 \mu s (0^{\circ}C \sim 45^{\circ}C)$ , Parameters as shown in figure 3-2:

Falling edge input delay:  $< 2 \mu s (0^{\circ}C \sim 45^{\circ}C)$ , Parameters as shown in figure 3-2:

- Line2/3 configured for input pin, camera internal equivalent circuit as shown in figure 3-6, Line2 as an example:

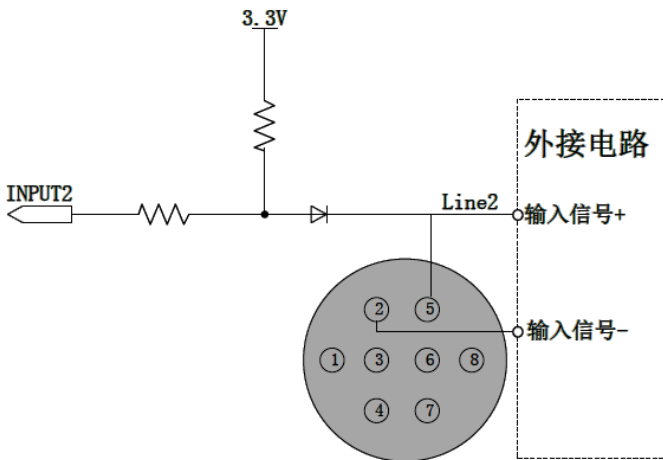

Picture 3-6 Line2 When configured as input pin camera internal equivalent circuit  
In order to prevent the GPIO pin is damaged, please connect to GND pin, then to Line2/3 pin input voltage.

Line2/3 configured to output pin:

An external voltage EXVCC range for 5V to 24V.

Line2/3 of the maximum output current of 25 ma, 40  $\Omega$  output impedance.

Typical application environment when the environment temperature 25 °C under the output voltage and output current of the table below:

| External voltage (EXVCC) | External resistance | Output voltage (V) | Output current (mA) |
|--------------------------|---------------------|--------------------|---------------------|
| 5V                       | 1K $\Omega$         | 0.19               | 4.8                 |
| 12V                      |                     | 0.46               | 11.6                |
| 24V                      |                     | 0.92               | 23.1                |

Rising along delay= $t_r+t_d$ :  $<20 \mu s$  ( $0^\circ C \sim 45^\circ C$ ), Parameters as shown in figure 3-4

Falling edge delay= $t_s+t_f$ :  $<20 \mu s$  ( $0^\circ C \sim 45^\circ C$ ), Parameters as shown in figure 3-4

Time delay parameters affected by the external power supply voltage, external pull-up resistance is bigger, affected by the temperature is very small. Typical application environment when the environment temperature 25 °C under the output of the delay time are shown in table:

| Parameter                              | Testing Conditions                                     | Value ( $\mu s$ ) |   |      |
|--|--|-------------------|---|------|
| storage time $t_s$                     | external power source 5V, pull-up resistor 1k $\Omega$ | 0.17              | ~ | 0.18 |
| delay time $t_d$                       |  | 0.08              | ~ | 0.09 |
| rise time $t_r$                        |  | 0.11              | ~ | 0.16 |
| fall time $t_f$                        |  | 1.82              | ~ | 1.94 |
| Rising along the time delay= $t_r+t_d$ |  | 0.19              | ~ | 0.26 |
| Falling edge delay= $t_f+t_s$          |  | 1.97              | ~ | 2.09 |

Line2/3 configuration for the output pin, the camera inside the equivalent circuit as shown in figure 3-7, Line2, for example:

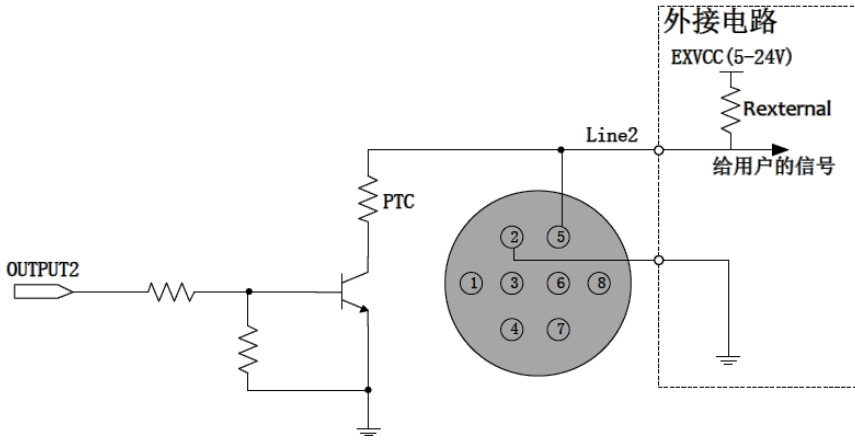

### Chapter Three: Work environment

#### 3.1 SRM1000 work environment:

|                       |                                     |
|-----------------------|-------------------------------------|
| voltage               | 24V DC                              |
| operating temperature | -10°C~50°C                          |
| storage temperature   | -20°C~60°C (non-condensation state) |
| relative humidity     | 10%~80%RH (non-condensation state)  |

#### 3.2 CCD camera work environment:

|                       |         |
|-----------------------|---------|
| voltage               | 12V DC  |
| Operating Temperature | 0~45 °C |

|                     |            |
|---------------------|------------|
| Storage Temperature | -20 ~70 °C |
| Operating humidity  | 10 ~80%    |

## Software article

### Chapter One: ADTVision function declaration

### Chapter One: ADTVision Interface specification

#### 1.1 Main Interface

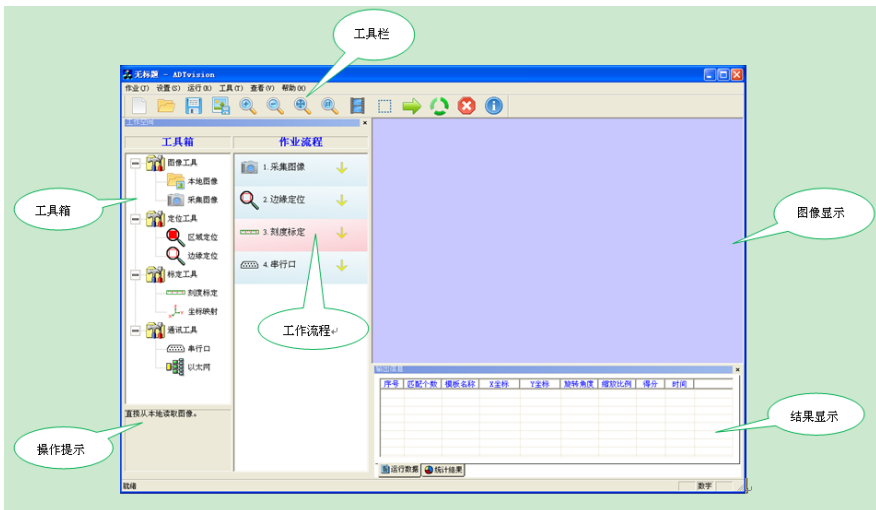

## 1.2 Main Toolbar



Create a new job



Open a job



Save the current job



Save image



Zoom view picture



Narrow display view picture



According to display images automatically ADAPTS to view images



Cancel the zoom in and out view picture



Click on the tool can into the acquisition mode



use ROI



perform a workflow



Automatic cycle workflow execution



Forced to stop, when there is infinite loop in the process



Displays version information and related information

### 1.3 Display area

Display area is used to display images and related graphic tools

### 1.4 Process area

Workflow bar list displays the current use of tools, click on the tools in columns can select tool, double-click the specific function of can pop-up tool information, can right-click pop-up menu, you can use the mouse drag and drop tool to adjust its position

### 1.5 The toolkit bar

Toolbar is a list of the current tools that can be used by a total of four major categories

- Image Tool: Used for image acquisition, storage, and pretreatment, etc
- setting tool: Used to add a template and set the localization algorithm
- Demarcate tool: To convert pixels to mm
- Communication Tool: Used to set the communication port and send and receive data and signals

### 1.6 output information

Includes statistical results and operation data, the results displayed in graphic mode, run data with precise Numbers.

## Chapter Two ADTVision operating instructions

### 2.1 New Project

Program starts will default to create a new empty project, click on the "new job" button in the toolbar, you can create a new job, if the current job changes not saved, will be prompted to save the current project.

Can click the "save" button in the toolbar, to save the current project to a file, save will pop up when save dialog for the first time, then save can directly replace the last file.

### 2.2 Process editor

Add tool when use left key of mouse drag tool from the toolbox to process column, use left key of mouse drag tool, tool location can be up or move down. Double-click on the tool can pop-up properties box, right-click the tool can pop-up properties box, and the tool item is removed from the process. Workflow tools in the combination configuration errors, if any, will appear in the configuration errors tip tool, tool configuration errors tail at the back of the icon will cross it. As shown in the figure below:





The process steps in the "right", click can pop-up "properties" and "delete" button,

-Properties: the pop-up tool function edit dialog.

-Delete: will the tool item is removed from the process.

## Chapter Three ADTVision Tool Introductions

### 3.1 grabbing image

Sampling image tools can be from camera images or add images from the file as a data source, commonly used in the beginning of the process.

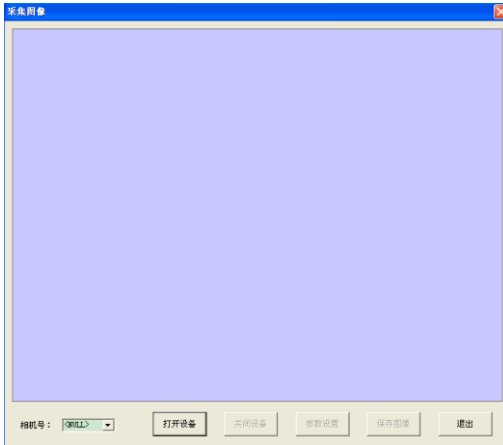

-Camera list: a list list of currently available camera

-Open the equipment: open the currently selected camera

-Shut down equipment: close the currently selected camera

-Parameter Settings: temporary unrealized

-Save the image: to save the currently displayed image to the specified directory

-Quit: quit the current module

### 3.2 Storing image

Store the image in the currently displayed frame to the specified directory, file called save time native system time.

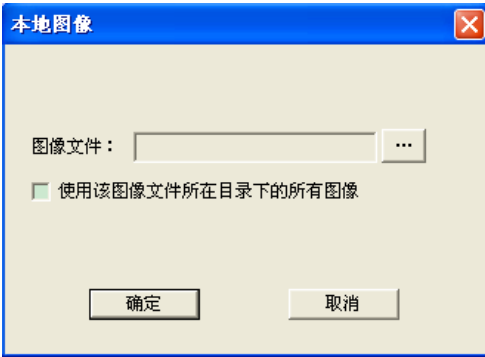

### 3.3 Setting Tool

#### 3.3.1 Based on the setting of regional orientation

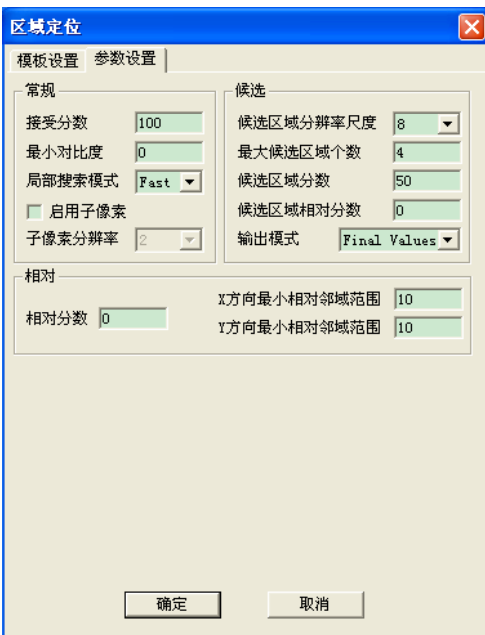

- Accept the score: the similarity exceeds this value when the match is considered to

| - Minimum contrast: brightness level than the black and white contrast, the greater the contrast, the more distinct color

| - Local Search Mode: Write enabled

| - Sub-pixel resolution: Write enabled

| - Resolution candidate region dimension: Write enabled

| - The maximum number of candidate areas: Write enabled | - Candidate region score: Write enabled

| - Candidate region relative score: Write enabled

| - Output mode: Write enabled

| - Relative Score: Write enabled

| -X Direction minimum relative neighborhood of: Write enabled

| -Y Direction relative to the minimum neighborhood of: Write enabled

### 3.3.2 Operation Template

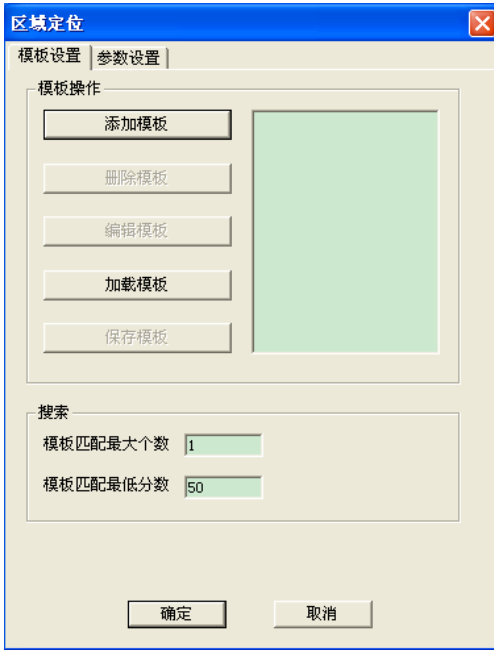

| - Add Template: Adds a learning template

| - Delete template: delete the selected template

| - Edit the template: a variety of factors template can be edited, as follows:



- Template rectangle size: Adjusting the size of the rectangular frame template
- The minimum angle of rotation: The minimum allowable angle of rotation, counterclockwise is positive
- The maximum rotation angle: maximum allowable angle of rotation, counterclockwise is positive
- Step angle of rotation: the smallest unit of count
- Rotate / Scale Width: Write enabled
- Rotate / Scale Height: Write enabled

### 3.3.3 Edge-based location settings

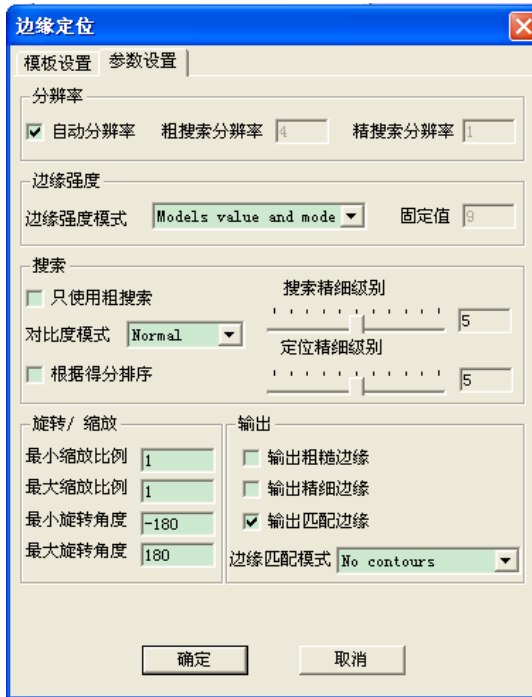

#### ● Auto Resolution: Write enabled

- Rough search Resolution: Write enabled
- Refined search Resolution: Write enabled
- Contrast Mode: Write enabled
- Search Fine level: Write enabled
- Fine Positioning level: Write enabled
- Minimum scale: The smallest contraction in multiples
- Maximum zoom ratio: The maximum magnification

- The minimum angle of rotation: The minimum allowable angle of rotation, counterclockwise is positive
  
  - The maximum rotation angle: Maximum allowable angle of rotation, counterclockwise is positive
  
  - Output rough edge: Write enabled
  
  - Output Fine Edge: Write enabled
  
  - Output matching Edge: Write enabled
  
  - Edge Match Mode: Write enabled
- | - The maximum number of template matching: most systems have many fewer templates
- | - Template matching the lowest score:

## 3.4 Calibration Tools

### 3.4.1 Scales calibration

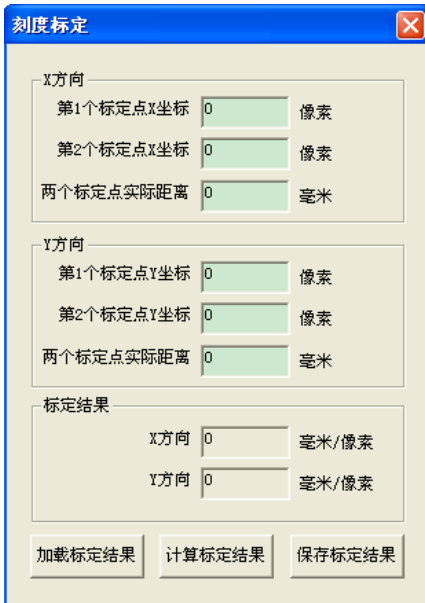

刻度标定

X方向

第1个标定点X坐标  像素

第2个标定点X坐标  像素

两个标定点实际距离  毫米

Y方向

第1个标定点Y坐标  像素

第2个标定点Y坐标  像素

两个标定点实际距离  毫米

标定结果

X方向  毫米/像素

Y方向  毫米/像素

加载标定结果    计算标定结果    保存标定结果

Enter two points x, y pixel coordinates and convert the actual coordinates of the c.

### 3.4.1 Coordinate mapping calibration



坐标映射

第1个标定  
像素坐标: X= 0 Y= 0  
机械坐标: X= 0 Y= 0

第2个标定  
像素坐标: X= 0 Y= 0  
机械坐标: X= 0 Y= 0

第3个标定  
像素坐标: X= 0 Y= 0  
机械坐标: X= 0 Y= 0

第4个标定  
像素坐标: X= 0 Y= 0  
机械坐标: X= 0 Y= 0

第5个标定  
像素坐标: X= 0 Y= 0  
机械坐标: X= 0 Y= 0

第6个标定  
像素坐标: X= 0 Y= 0  
机械坐标: X= 0 Y= 0

第7个标定  
像素坐标: X= 0 Y= 0  
机械坐标: X= 0 Y= 0

第8个标定  
像素坐标: X= 0 Y= 0  
机械坐标: X= 0 Y= 0

第9个标定  
像素坐标: X= 0 Y= 0  
机械坐标: X= 0 Y= 0

加载标定结果 计算标定结果 保存标定结果

Enter the coordinates of nine points, the calibration results after positioning algorithm by 9:00 mapped directly to the actual coordinates, especially for the robot coordinate system conversion.

## 3.5 Serial Port

RS232 serial port settings, and external devices for data transmission

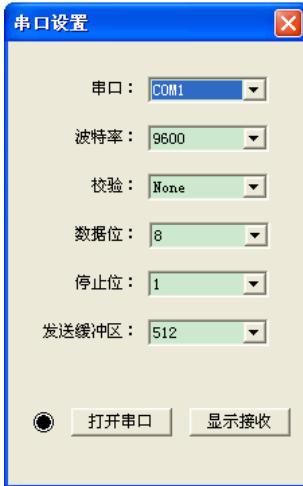

Set the serial port baud rate, parity, data bits, stop bits, buffer zones and other parameters for serial communication, output the positioning result.

### 3.6 Ethernet

Ethernet communications port, and external devices for data transmission

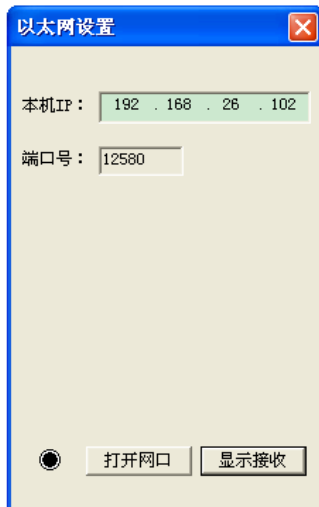

Network communication, transmission positioning results through the server

access to the machine.

### Appendix I Common problems in the camera

| No. | common problem  | Solution   |
|-----|---|--|
| 1   | The camera began collecting no image                                  | (1) Make sure the camera is set packet length is greater than 1500, and the host is not a huge frame mode, modify the host for the giant frame mode;<br>(2) load the default parameter set, re-open the program and start collecting again, to confirm whether the image;<br>(3) open demo program, open the properties configuration page, view the configuration of the traffic confirm whether the received data packet, if the packet, but are runts, please confirm in accordance with the use of Environmental Considerations; |
| 2   | The frame rate is less than the nominal value                         | (1) replacement of the host, the choice of a better performance of the host;<br>(2) with the recommended series Intel Gigabit Ethernet;<br>(3) contact the company for technical support;  |
| 3   | When using multiple cameras at the same time frame dropping seriously | (1) The adjustment package or bag length interval parameter, this approach will seriously reduce the frame rate<br>(2) the use of multiple network adapters that are connected to the camera on a different card, to share network bandwidth   |

|   |   |  |
|---|---|--|
| 4 | <p>On the inactive Win7 64-bit machines, installation package MER_setup_cn.exe MER-series cameras, the installation process and not an error, unable to open the demo program</p> | <p>(1) enter the activation code in Win7 under the system is activated, the installation package to uninstall and re-install restart the system, open the presentation again</p>   |
| 5 | <p>Open the equipment fails, prompts parse XML file errors</p>  | <p>(1) re-equipment online upgrade, to be confirmed after the success of online upgrade, re-open device</p>  |
| 6 | <p>After modifying packet interval to a higher value, the image cannot be received</p>  | <p>(1) See the list of attributes of the demonstration program, confirm the configuration of the data stream at block timeout, turn up the property set until it receives the image data</p>   |
| 7 | <p>Less than an enumeration camera under Windows XP</p>   | <p>(1) Check the network connection, whether there is connection<br/>                 (2) repeated enumeration, whether successful enumeration<br/>                 (3) modify the host IP address, once again successful enumeration, enumeration, if successful, to confirm whether the camera's current IP address of the host before the same address, if different, change the IP address of the host or camera</p> |

# Revision History (1)

|                     |  |                         |  |   |  |
|---------------------|--|-------------------------|--|---|--|
| Feedback person     |  | Feedback Date           |  | The current version / total number of pages |  |
| Problem Description |  |                         |  |   |  |
| engineer confirm    |  |                         |  |   |  |
| The revised version |  | The revised total pages |  | Revision people                             |  |